

1. Definitions

- 1.1 In this Annex, a reference to a clause or appendix unless stated otherwise, is to a clause of or appendix to this Annex. Words and expressions have the meanings given to them in the definitions section of the main body of this FVCT Agreement.

2. Recording of Billing Information

- 2.1 Vodafone shall for each individual Call or Switch Port collect, record (whether in bulk or on an itemised Call basis) and process the Billing Information in accordance with paragraph 2.2 and/or paragraph 2.3 (as the case may be).
- 2.2 The following shall be recorded for each Call relevant to the Interconnect Services in Service Schedules 1 and 4:
- (a) Interconnect Node identifier; and
 - (b) the dialled digits and/or such other information as may be agreed; and
 - (c) CLI (if available); and
 - (d) the date and time when the Answer Signal is received by Vodafone; and
 - (e) chargeable Call duration (whether measured or derived) and
 - (f) the RIO Service involved to the level of detail specified in the relevant Service Schedule.
- 2.3 The following shall be recorded for each Switch Port:
- (a) Circuit number
 - (b) A-end address
 - (c) B-end address
 - (d) Circuit type

3. Exchange of Billing Information

- 3.1 Vodafone shall process the information specified in paragraph 2.2 so as to produce the matrix outlined below in Table A.1 or such other matrix as the Parties may from time to time agree (which shall be referred to as the Vodafone Interconnect Call Usage Report).

Table A.1

CALL TYPE				
Fixed TERMINATION	Period	Total Number of Calls	Total Duration	TOTAL REVENUE
	Peak			
	Off Peak			
	Weekend			
		ΣN	ΣM	ΣR

Where: N = the total number of Calls
M = the total duration of Calls
R = the total Revenue Chargeable Duration:
M x Rate per minute; or
N x Rate per call; or
M x Rate per minute plus N x Rate per call

- 3.2 Vodafone shall process the information specified in paragraph 2.3 so as to produce the matrix below in Table A.2 or such other form of Switch Port Report as the Parties may from time to time agree (which shall be referred to as an Vodafone Switch Port Report):

Table A.2

CIRCUIT NUMBER	A-END ADDRESS	B-END ADDRESS	CIRCUIT TYPE	INSTALLATION CHARGE	RENTAL	TOTAL AMOUNT DUE

- 3.3 The Billing Information shall be provided to OAO together with the resulting invoice not earlier than two (2) weeks and not later than five (5) weeks after the end of each Billing Period. The Billing Periods for Interconnect traffic shall be monthly commencing from 00.00 hours on the 1st day of each calendar month and the Billing Periods for Switch Ports shall be quarterly commencing from 00.00 hours on the 1st day of each calendar quarter (1st January, 1st April, 1st July and 1st October).
- 3.4 Vodafone shall store the Billing Information for a period of 24 months after each Billing Period. Billing Information shall be stored in such summary format and in such amounts as shall be sufficient to recalculate the amounts due from one Party to the other and to take account of changes in the relevant prices.
- 3.5 If the Parties' monitoring of Billing Information indicates a persistent inconsistency in reconciling Billing Information provided by the Parties' respective Billing Systems, the Parties shall use their reasonable endeavours to ascertain the cause of such inconsistency, including, subject to the Parties agreement, the reference of the matter for investigation and resolution by such appropriate independent consultant as the Parties may agree, or in default of agreement, as may be nominated by the President for the time being of the Institute of Chartered Accountants in Ireland. Such independent consultant shall act as an expert and not as arbitrator and his decision, in the absence of manifest error, shall be final and binding. The Parties shall co-operate in such investigation. The independent consultant's costs for such investigation shall be paid by the Parties in such proportions as the independent consultant shall decide.
- 3.6 In the event of previously undetected errors in the Billing Information which resulted in the production of an incorrect invoice reflecting either an under-payment or an over-payment, either Party may request a review of the Billing Information for any Billing Period within 24 months of the date of the end of that Billing Period. The Party requesting such a review must accompany the request with a reasonable estimate of amount which may be under-paid or over-paid for the period in question and which forms the basis for the review request.
- 3.7 In the event of the Billing Information not being available to Vodafone in time to produce the monthly invoice, the Parties agree that an invoice may be produced based on estimated Billing Information. This estimate shall be derived using the following formula for the required detail of each separate traffic stream in the Service Schedules:
- $$\text{traffic month } N = \text{traffic month } (N-1) * (\text{traffic month } (N-1) / \text{traffic month } (N-2))$$
- 3.8 Vodafone must advise OAO of the fact that any invoice is estimated together with the reasons for using estimates.
- 3.9 Vodafone must issue a standard (non-estimated) invoice to cover the same period as the estimated invoice within 3 months of the issue of the estimated invoice.
- 3.10 If Vodafone is unable to issue a standard invoice for any reason within this period then the estimated invoice shall be treated as final and may not be subsequently amended except in the case of a Billing Dispute. For the avoidance of doubt, the terms of paragraph 6 below shall apply to estimated invoices.

4. Invoices

- 4.1 At the end of a Billing Period for Interconnect Traffic Vodafone shall submit to OAO an invoice for Charges for Calls as outlined in paragraph 3 of this Annex I and any other Charges for which Vodafone is entitled to charge the other Party during such Billing Period.
- 4.2 At the end of a Billing Period for Switch Ports Vodafone shall submit to OAO an invoice for Switch Port Charges as outlined in paragraph 3 of this Annex I and any other charges for which Vodafone is entitled to charge the other Party. Where applicable a Switch Port Report in the format required in paragraph 3 shall also be submitted.
- 4.3 All Charges payable under this Agreement shall be calculated in accordance with this Agreement and at the rates specified from time to time in the Service Schedules or in Annex IV (as is appropriate). Invoices raised under this Agreement shall be paid in accordance with clause 8 of the main body of this Agreement.
- 4.4 For the avoidance of doubt, an invoice (including an invoice based on estimated information) shall be dated as of the date of dispatch of that invoice.
- 4.5 For Data Management Amendments Vodafone shall provide the appropriate Billing Information with the invoice to enable OAO to accurately process the invoice for same.

5. Payment

- 5.1 Subject as stated below, all charges due by one Party to the other under this Agreement shall be payable by the Due Date.
- 5.2 If, pursuant to paragraph 6.1 of this Annex I, OAO has notified Vodafone of a dispute relating to an invoice and such dispute has not been resolved before the Due Date, and if the amount in dispute represents:
- (a) less than five (5) per cent. of the total amount (excluding VAT) of the relevant invoice, the total amount invoiced shall be due and payable on the Due Date.; or
 - (b) five (5) per cent. or more of the total amount (excluding VAT) of the relevant invoice, the amount in dispute may be withheld until the dispute is resolved and the balance shall be due and payable on the Due Date.
- 5.3 Notwithstanding notification of a dispute pursuant to clause 6, if OAO fails to pay any amount due under this Agreement on the Due Date or overpays any amount, the payee or, as the case may be (subject to clause 5.5) the over-payer, shall pay or be paid (as is appropriate) interest at the Default Interest Rate from the Due Date or date of the overpayment in respect of any such amount.
- 5.4 Interest at the Default Interest Rate shall be payable (for late payment) from and including the Due Date or, in the case of overpayment and refund, the later of (a) the date of payment of the original amount to be refunded and (b) the Due Date, in each interest shall cease to accrue on the date of payment or, as the case may be, refund in full. Interest at the Default Interest Rate shall accrue day by day and shall not be compounded.
- 5.5 If an overpayment results from information provided by the over-payer (which is not attributable to information provided by the payee), the payee shall be under no obligation to pay interest (whether at the Default Interest Rate or otherwise) on the amount overpaid.
- 5.6 VAT shall be added to all or any part of the Charges charged under this Agreement and shall be paid by the Party responsible for making such payment.

6. Disputes

- 6.1 A Billing Dispute can only be raised where a financial value can be identified as a dispute and where OAO maintains, through reasonable comparison methods, that their equivalent financial

values are different to those contained on the invoice (a “Billing Dispute”). Financial values can differ, for example, where traffic volumes, traffic routing, products included and/or rates charged, do not correspond. Any Billing Dispute raised that is not in accordance with the procedures of this paragraph 6 will not be accepted by Vodafone and will not be governed by this Billing Dispute Procedure. Each Party shall use its reasonable endeavours to resolve Billing Disputes with the other.

6.2 If OAO disputes the accuracy or content of an invoice delivered pursuant to this Agreement OAO shall:

- (a) notify Vodafone in writing, no later than 1 Working Day prior to the Due Date of the disputed invoice if monies are being withheld, or within 24 months of the date of the end of that Billing Period, that it intends to raise a Billing Dispute. This notification shall be accompanied by all relevant details of the Billing Dispute. Where traffic volumes are being disputed, OAO shall forward, in soft copy, traffic details specifically for the disputed period as follows:
 - (i). total daily minutes for the FVCT Service under dispute, distilled by the relevant Interconnect Node and the relevant Interconnect Route.
 - (ii). total daily Calls for the FVCT Service under dispute by the relevant Interconnect Node and the relevant Interconnect Route.
- (b) Notification shall be in the form set out in Annex B, Appendix 1.
- (c) Receipt of a Billing Dispute notice commences a Phase 1 Investigation.

6.3 Vodafone shall:

- (a) within five (5) Working Days of receipt of the notice referred to in paragraph 6.2(a) acknowledge the receipt of such notice in writing; and return their equivalent details (as outlined in paragraph 6.2(a)) to OAO.
- (b) carry out an appropriate investigation of the disputed matters within fifteen (15) Working Days of the receipt of the information referred to paragraph 6.2(a) (a “Phase 1 Investigation”).

6.4 If the Billing Dispute is not resolved to both Parties’ satisfaction within thirty (30) Working Days of the exchange of information referred to in paragraph 6.2, the Parties shall, on day 31, exchange call detail records (CDRs) relevant to the issue in dispute (a “Phase 2 Investigation”). This should only include information for switches, routes and Interconnect Services that have been identified in the earlier phases of investigation as the most likely source of discrepancy between the Parties.

Phase 2 Investigations shall be completed by the Parties no later than thirty (30) Working Days after the CDR exchange. All CDR information exchanged should contain the following details:

Calling Party Number	Called Party Number	Date For Start of Charge	Time For Start Of Charge	Chargeable Duration	Interconnect Route	Interconnect Node

6.5 If following the Phase 2 Investigation, the Billing Dispute is not resolved to the satisfaction of both Parties, then either Party may (by written notice to the other to such effect) refer the Billing Dispute to a Phase 3 Investigation. Phase 3 Investigation shall comprise of an examination and resolution of the dispute by such chartered accountant as the Parties may agree, or in default of

agreement, as may be nominated by the President for the time being of the Institute of Chartered Accountants in Ireland. Such chartered accountant shall act as an expert and not as arbitrator and his/her decision, in the absence of evidence of manifest error, shall be final and binding. The Parties shall co-operate in such investigation and, if any sums are found to be due or overpaid by either Party in respect of the disputed invoice such sum shall be paid or refunded (with interest payable or paid pursuant to paragraph 5.3), as the case may be, within twenty (20) Working Days from the date of resolution or earlier settlement between the Parties.

- 6.6 The costs of the chartered accountants agreed or nominated shall be paid by OAO unless the relevant invoice is established to have been incorrect, or unless the expert determines it reasonable to apportion or ward the costs on some other basis
- 6.7 Except if otherwise specifically provided, all Billing Dispute correspondence shall be sent as follows:

Billing Dispute Contacts	
Notices to Vodafone	Notices to OAO
Billing Operations Manager Vodafone Interconnect Vodafone Ireland MountainView Leopardstown Dublin 18.	[tbc]
Telephone: 087 6875969	
Email: noel.egan@vodafone.com	

- 6.8 It shall be the responsibility of each Party to ensure that the information set out above is accurate. In the event of any change in detail, it shall be that party's obligation to notify the other party in accordance with clause 26 of the main body of this Agreement.
- 6.9 Each Party shall use the above Billing Dispute resolution procedure for any Billing Dispute to the fullest extent to try to resolve such billing disputes. Either Party may seek to extend the above timescales for reasonable reasons, for example but not limited to, complexity of issues or data, such as back-billed data. The Party receiving such an extension request shall act reasonably in responding to such requests. The extension request shall be in the form set out in Appendix II to this Annex I and shall be sent pursuant to paragraph 6.7. The Party receiving the request shall respond pursuant to paragraph 6.7.
- 6.10 If a Party fails to comply ("the Defaulting Party") with any of the provisions and time-scales relating to Phase1 Investigations or Phase 2 Investigations, the other Party ("the Compliant Party"), shall issue a notice of such failure to comply ("Failure to Comply Notice") as set out in Appendix III to this Annex I. Failure to issue a Failure to Comply Notice shall not constitute a default or be used as the basis to issue a Failure to Comply Notice. A Failure to Comply Notice can be sent to a different contact from the Billing Dispute Contact if agreed by the Parties, such Agreement not reasonably withheld.
- 6.11 The Parties have agreed to include in this Agreement separate points of contact for the receipt of Failure to Comply Notices.

Failure to Comply Notices	
Notices to Vodafone	Notices to OAO
Billing Operations Manager Vodafone Interconnect Vodafone Ireland MountainView Leopardstown Dublin 18.	[tbc]
Telephone: 087 6875969	
Email: noel.egan@vodafone.com	

- 6.12 Subsequent to the receipt of a Failure to Comply notice, should the Defaulting Party rectify the matter of non-compliance within aforementioned the 2-week timeframe, the Billing Dispute shall recommence at the appropriate stage in the Billing Dispute Procedure timeline.
- 6.13 At the conclusion of the aforementioned 2-week timeframe following the issue of a Failure to Comply Notice, if the Defaulting Party has failed to comply with any of the provisions and time-scales relating to the investigation or as otherwise agreed in writing by the Parties, the Billing Dispute shall be deemed resolved in favour of the compliant Party and that the compliant Party shall be fully entitled to payment of the full amount of the disputed invoice or credit together with interest payments at the Default Rate on such an amount calculated from the Due Date as more particular described above.
- 6.14 The above Billing Dispute Procedure is without prejudice to any other rights and remedies that may be available to a Party under this Agreement or in law in respect of any breach of any provision of this Agreement.
- 6.15 Subject to the above, all disputed amounts shall be payable on resolution of the relevant Billing Dispute within ten (10) Working Days (together with applicable interest at the Default Interest Rate on any amount withheld by OAO in the event that Vodafone is found not to be in fault). The amount owed and the interest owed on that amount will be billed on separate invoices.
- 6.16 Though it is the good faith intention of the Parties to use the above Billing Dispute Procedures to the fullest extent to resolve Billing Dispute, nothing in this Annex shall prevent either Party seeking, obtaining or implementing interlocutory or other immediate relief in respect of any Billing Dispute or in accordance with any right it may have under its Authorisation or Licences from referring any matter relating to this Annex or any Billing Dispute to ComReg requesting ComReg to make a determination or take other appropriate steps for resolution.
- 6.17 A formal acceptance of Billing Dispute closure shall be necessary for each specific Billing Dispute, notwithstanding a Party's right to dispute other parts of the same invoice. This acceptance shall be in the form set out in this Appendix IV to Annex I and it shall be signed by both Parties once the dispute is concluded as provided for in this Billing Dispute Procedure.

7. Credit

- 7.1 Both Parties agree that a credit will be issued in order to cancel either the total charge of an incorrect invoice or an incorrect part-charge on an invoice (a "Credit").
- 7.2 Prior to issue of a Credit the Parties shall confirm the correct value of the Credit. Confirmation by email or fax will suffice.
- 7.3 Vodafone shall issue a Credit in the following circumstances:
- (a) the resolution of a dispute under paragraph 6 confirming that a Credit is due; or
 - (b) any mutual agreement by the Parties that a Credit is due.
- 7.4 Both Parties confirm that they shall use their best endeavours to agree the value of Credit due and resolve any disputes as soon as possible or within the timeframe agreed in paragraph 6.
- 7.5 Both Parties agree that the Credit will be issued within twenty (20) calendar days of agreement/determination of the matter and that the original invoice number and/or dispute reference number shall be detailed with the appropriate Credit.

8. Supplementary Invoices

- 8.1 A supplementary Invoice can be issued in accordance with the terms of this Agreement in order to recover charges arising from the under-billing of Interconnect Services or as a result of agreement in that regard between the Parties.

- 8.2 Both Parties, prior to issue of the Supplementary Invoice, should confirm that the value is correct. Confirmation will suffice by email or fax.
- 8.3 Vodafone, in the following circumstances, shall issue a Supplementary Invoice:
- a) The Resolution of the Dispute under clause 6 confirms that a Supplementary Invoice is applicable.
 - b) any mutual agreement by the parties that a Supplementary Invoice is applicable
- 8.4 Both Parties confirm that they shall use their best endeavours to agree the value of any supplementary invoice issued and resolve any disputes as soon as possible or within the timeframe agreed in the Dispute Resolution Procedure. However, the time frames specified in paragraph 6 may be extended by mutual agreement if such action is deemed necessary by both Parties in order to resolve a dispute relating to supplementary invoices.
- 8.5 On agreement by both Parties that the value is correct, Vodafone should immediately issue the supplementary invoice and OAO shall pay the amount within ten (10) days.
- 8.6 The original invoice number and/or dispute reference number shall be detailed with the Supplementary Invoice.

**Appendix I
Billing Dispute Notification Form**

Company Name	OAO	Invoice being Disputed:	
Company Address		Invoice Amount:	
Email		Invoice Date:	
Contact Name.		Amount being Disputed:	
Contact Number		Billing Dispute Reference:	

Specific Billing Dispute Details

This Dispute relates to -----(e.g. Traffic Volumes, rates are incorrect)

- This is to inform Vodafone that OAO intends to apply the Billing Dispute Procedures as per paragraph 6 of Annex I of the signed FVCT Agreement between the Parties.
- Summary of Billing Dispute – Fill as appropriate.
- This form is to be accompanied by detailed information on Billing Dispute in accordance with paragraph 7 of Annex I the FVCT Agreement between the Parties.

Service Schedule Affected	Nature of Discrepancy			Comments
	Calls	Duration	Charge	
	Invoice Total			
	Own Total			
	Invoice Total			
	Own Total			
	Invoice Total			
	Own Total			

Signed: _____

Date: _____

Appendix II
Time Extension Request

Company Name

Invoice being Disputed:

Company Address

Billing Dispute Reference:

Contact Name.

Email

Contact Number

Company X wishes to request that Company Y agree to extend the timelines associated with this Billing Dispute.

Reason for the extension request:

Period of extension required:

Signed: _____
Company X

Date: _____

Company Y informs Company X that it accepts/rejects Company X's request to extend the timelines associated with this Billing Dispute.

Reason for Rejection:

Signed: _____
Company Y

Date: _____

Appendix III
Failure to Comply Notice

Company Name

Invoice being Disputed:

Company Address

Billing Dispute Reference:

Contact Name.

Email

Contact Number

Pursuant to paragraph 6.10 of Annex I, **Company X** informs **Company Y** of its failure to comply with the Billing Dispute Procedure.

Company Y has failed to comply with the timeframes/provision of information requirement of the Billing Dispute Procedure.

Specific Failure to Comply Details:

Upon correction of this non-compliance within two weeks of the date of issue of this Notice, the Billing Dispute Procedure shall recommence at the appropriate stage in the timeline.

Should **Company Y** fail to rectify this matter within the two-week timeframe, this Billing Dispute will be deemed resolved in favour of **Company X**.

Signed: _____
Company X

Date: _____

Company X Name**Company Y** Name

--

Company X
Address**Company X**
Address:

--

Contact Name.

Contact Name.

Contact Number

Contact Number

Email

Email

Invoice being
Disputed:Amount being
disputed:Billing Dispute
Reference:

Invoice Date:

Company X accepts that this Billing Dispute has been resolved in favour of **Company Y**. **Company Y** will forward €_____ to **Company Y** within ten (10) Working Days of resolution. Resolution of this specific Billing Dispute does not prevent either Party disputing a different aspect of this same invoice.

Signed: _____
Company X

Date: _____

Company Y accepts that this Billing Dispute has been resolved in favour of **Company X**. **Company Y** will forward €_____ to Operator X within ten (10) Working Days. Resolution of this specific Billing Dispute does not prevent either Party disputing a different aspect of the same invoice.

Signed: _____
Company Y

Date: _____

**ANNEX II
INDEX OF INTERCONNECT SERVICES**

SERVICE SCHEDULE NUMBER	SERVICE TITLE
Vodafone Services	
A1	Vodafone Fixed Voice Call Termination
A3	Vodafone Customer Care Access
Joint Services	
C1	Data Management Amendment

**ANNEX II
SERVICE SCHEDULE A1**

VODAFONE FIXED VOICE CALL TERMINATION

This Service Schedule is effective from the date of execution of the Agreement and shall remain in effect until amended following agreement of the Parties to such amendment.

1. Definitions

- 1.1 In this Service Schedule A1, a reference to a clause or appendix unless stated otherwise, is to a clause or appendix of this Service Schedule. Words and expressions have the meaning given in the main body of the Agreement.

2. Description of Service

Subject to the provisions of this Service Schedule, Vodafone shall terminate **Fixed** Voice Calls received from the OAO Network for delivery on the Vodafone Network.

3. Terms and Conditions

- 3.1 The Parties shall agree in advance all necessary technical requirements, including Call set-up and clear-down sequences, for the termination of Vodafone Fixed Voice Call Termination Calls pursuant to this Service Schedule.
- 3.2 Vodafone shall terminate Vodafone Fixed Voice Call Termination Calls, incoming from the OAO Network, during those periods of time and at the same standard and quality of service as it terminates similar calls originated within its own Network.
- 3.3 The Parties shall correct faults which occur in their respective Networks which affect the origination and termination (as applicable) of Vodafone Fixed Voice Call Termination Calls in accordance with each Party's normal engineering practices. For the avoidance of doubt, neither Party warrants that its Network is, or will be, free from faults.
- 3.4 Where OAO has access to the National Porting Database and utilises same for the routing of Calls, OAO agrees to keep and maintain its information in respect of the National Porting Database accurate and up-to-date. OAO further agrees to up-date the National Porting Database data that it utilises for Call routing in a timely manner and to hand-over Calls to the correct terminating fixed network operator.
- 3.5 OAO acknowledges that the hand-over of calls to the incorrect terminating fixed network operator on the basis of an incorrect routing prefix and/or failure to convey calls to the correct terminating fixed network operator may result in the non-conveyance and/or non-termination of such Calls. In the absence of a separate and express agreement between the Parties for such a service, Vodafone shall be under no obligation to terminate such Calls or to forward such calls to the correct terminating fixed network operator.
- 3.6 Where OAO does not have access to the National Porting Database or hands over traffic to Vodafone solely on the basis of number ranges/network access codes ('NAC') originally allocated to Vodafone and for calls to numbers other than those hosted on the Vodafone Network at the time of the call OAO shall discharge all transit and subsequent termination costs incurred by Vodafone as a result of the conveyance of such Call to the appropriate terminating fixed network operator.
- 3.7 Where the parties have signed a service schedule for "Conveyance of Calls to Ported Fixed Numbers" such onward routing shall be governed by the terms of this service schedule
- 3.8 Where the parties have not signed a service schedule for "Conveyance of Calls to Ported Fixed Numbers" Vodafone's assessment of such calls and its calculation of the transit and termination charges in respect thereof shall, in the absence of manifest error, be conclusive. Notwithstanding any clause to the contrary contained herein, Vodafone shall be sole arbiter of costs incurred by it for the termination/transit of the Calls described in this clause 3.8 and the originating Party shall not be entitled to invoke the dispute resolution procedure set out in clause 17 of the main agreement in respect of such charges.

4. Routing

- 4.1 The termination of Vodafone Fixed Voice Call Termination Calls shall be in accordance with the routing principles specified in the Network Plan and all such calls shall be delivered to the Vodafone Interconnect Node on OAO Interconnect Paths.

- 5.1 For the termination of Vodafone Fixed Voice Call Termination Calls from the OAO Network, OAO shall pay Vodafone a charge calculated in accordance with the rates as specified in the Vodafone FVCT Pricelist as amended from time to time.

Interconnect

**ANNEX II
SERVICE SCHEDULE A3**

VODAFONE CUSTOMER CARE ACCESS

This Service Schedule is effective from the date of execution of the Agreement and shall remain in effect until amended following agreement of the Parties to such amendment.

1. Definitions

- 1.1 In this Service Schedule A3 a reference to a clause or appendix unless stated otherwise, is to a clause or appendix of this Service Schedule. Words and expressions have the meaning given in the main body of the Agreement.

2. Description of Service

- 2.1 Subject to the provisions of this Service Schedule 3, OAO shall convey Vodafone Customer Care Access Calls originating on the OAO network to the Vodafone Network. This shall comprise all traffic with the digits 1907.

3. Terms and Conditions

- 3.1 The Parties shall agree in advance all necessary technical requirements, including Call set-up and clear-down sequences, for the conveyance of Vodafone Customer Care Access Calls pursuant to this Schedule.
- 3.2 OAO shall convey Vodafone Customer Care Access Calls during those periods of time and at the same standard and quality of service as OAO originates and conveys similar calls originated within the OAO Network.
- 3.3 The Parties shall correct faults which occur in their respective Networks which affect the conveyance of Vodafone Customer Care Access Calls in accordance with each Party's normal engineering practices. For the avoidance of doubt, neither Party warrants that its Network is, or will be, free from faults.

4. Routing

- 4.1 The conveyance of Vodafone Customer Care Access Calls shall be in accordance with the routing principles specified in the Network Plan and all such Calls shall be delivered to Vodafone Interconnect Nodes. All calls in this Service Schedule will be carried on Vodafone Interconnect Paths.

5. Charging

- 5.1 For the conveyance of Vodafone Customer Care Access Calls from OAO Network, Vodafone shall pay OAO a charge calculated in accordance with the rates as specified in the table below.

Number Range	Charge
1907	Free

Data Management Amendment

This Service Schedule is effective from the date of execution of the Agreement and shall remain in effect until amended following agreement of the Parties to such amendment.

1. Definitions

- 1.1 In this Service Schedule, a reference to a clause or Appendix unless stated otherwise, is to a clause or Appendix of this Schedule. Words and expressions have the meaning given in the main body of the FVCT Agreement.

2. Description of Service

- 2.1 Subject to the provisions of this Service Schedule, the Requested Party shall implement agreed Data Management Amendments within its Network in accordance with clause 10 of the FVCT Agreement. The Requested Party shall notify the Requesting Party on completion.

3. Charging

- 3.1 The Vodafone charges for implementation of a Data Management Amendment are outlined in Table 1 below. In the event that OAO should request implementation of more than one amendment at the same time, a 50% discount shall apply for all such requests.

Table 1

Charging Element	Charge
Data Transcript Charge (Minimum Price)	€ 2849.29
Implementation Charge per Interconnect Node(Minimum Price)	€ 502.82

- 3.2 OAO charges for implementation of a Data Management Amendment are outlined in Table 1 below. In the event that Vodafone should request implementation of more than one amendment at the same time, a 50% discount shall apply for all such requests.

Table 1

Charging Element	Charge
Data Transcript Charge (Minimum Price)	€ 2849.29
Implementation Charge per Interconnect Node(Minimum Price)	€ 502.82

TABLE OF CONTENTS

The following represents a typical interconnect regime for fixed traffic. Details of the final arrangements will be agreed between the interconnecting parties in advance.

- 1. Definitions**
- 2. Objective**
- 3. Location of Interconnect Nodes**
- 4. Transmission Characteristics of Interconnect Links**
- 5. Traffic Routing Principles**
- 6. Signalling Interface**
- 7. Numbering Plans, Digit Analysis**
- 8. Service Quality**

1. Definitions

In this Annex, a reference to a clause or Appendix unless stated otherwise, is to a clause or Appendix of this Annex. Words and expressions have the meaning given in Annex A.

2. Objective

This document forms part of the Agreement. This document deals with planning and design. It provides the technical basis to define the characteristics of the interface.

3. Location of Interconnect Nodes

3.1 The Interconnect Node(s) as offered by OAO shall be as follows:

[tbc]

3.2 The Interconnect Nodes as offered by Vodafone shall be as follows:

[tbc]

4. Transmission Characteristics of Interconnect Links

The Interconnect Network shall be established using 2Mbit/s PDH technology. Capacity will be increased in units of 1 * 2 Mbit/s Interconnect Paths, or multiples thereof.

4.1 Physical Interconnect Configuration

Capacity provided to complete traffic from OAO to Vodafone should be unidirectional with each OAO Interconnect Node being meshed to at least two Vodafone Interconnect Nodes.

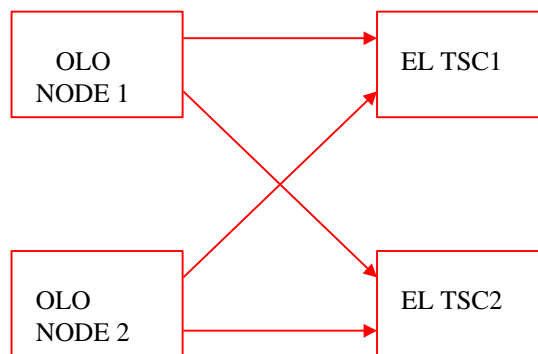

Fig 4.1.1 Sample Interconnect configuration between OAO and Vodafone.

Capacity provided to complete traffic from Vodafone to OAO should be unidirectional with each Vodafone Interconnect Node being meshed to at least two OAO Interconnect Nodes.

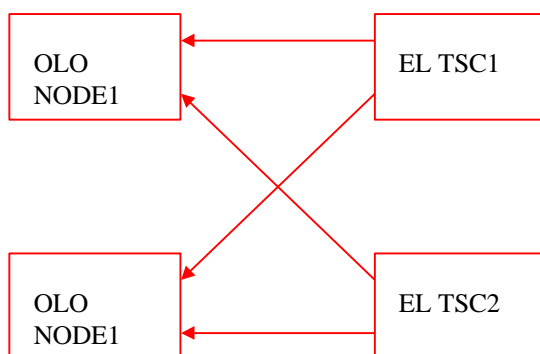

Fig 4.1.2 Sample Interconnect configuration between Vodafone and OAO

5. Traffic Routing Principles

5.1 OAO traffic towards the Vodafone Interconnect Nodes

The OAO Network should implement load sharing of all traffic types (as defined in the Service Schedules) such that an equal proportion of each traffic type is offered to each Vodafone Interconnect Node. In the event of unavailability of the Interconnect Network or part thereof then the OAO Network shall implement alternative routing as follows:-

- (1) both meshed Interconnect Links from the first OAO Interconnect Node are attempted;
- (2) both meshed Interconnect Links from the second OAO Interconnect Node are attempted;
- (3) traffic is routed via PSTNs.

5.2 Vodafone Traffic towards the OAO Interconnect Nodes

The Vodafone Network will implement load sharing of all traffic types (as defined in the Service Schedules) such that an equal proportion of each traffic type is offered to each OAO Interconnect Node. In the event of unavailability of the Interconnect Network or part thereof then the Vodafone Network shall implement alternative routing as follows:-

- (1) both meshed Interconnect Links from the first Vodafone Interconnect Node are attempted;
- (2) both meshed Interconnect Links from the other Vodafone Interconnect Node are attempted;
- (3) traffic is routed via PSTNs.

6. Signalling Interface

6.1 Signalling Protocols

Protocols will be agreed between the parties subject to the most efficient arrangements being agreed.

6.1.1 Calling Line Identification

The introduction of Calling Line Identification shall be as defined in clause 12.2 of the main body of the Agreement. Both parties will provide CLI presentation as defined by ISUP specification documents, ITU-T ISUP '92, Q761-766 and ETSI ISUP V2: ETS 300 356-1..19 (Feb '95).

6.2 Specific SCCP requirements

6.2.1 SCCP Translation

The SCCP functionality is active in the OAO /Vodafone Interconnect Nodes. All relevant messages will use this translation functionality.

7. Traffic

To be agreed between the parties in line with standard approaches.

7.1. OAO traffic towards the Vodafone Network

OAO will pass to Vodafone the calling party number in E164 format. The Nature of Address Indicator will be set to National. The CLI will appear in National Format.

note 1:

OAO will pass to an Vodafone Interconnect Node, Called Party numbers in the national number format only (excluding the trunk access prefix zero),

7.2. Vodafone traffic towards the OAO Network

Vodafone will pass to OAO the calling party number in E164 format. The Nature of Address Indicator will be set to National. The CLI will appear in National format.

note 2:

Vodafone will pass to an OAO Interconnect Node, Called Party numbers in the national number format only (excluding the trunk access prefix zero), i.e. [] XXXXXXXX, (9 Digits) or in the case of voicemail access [] XXXXXXXX, (10 Digits). Calls from the Vodafone Network to the OAO Network are routed by analysis of the second digit dialled only,

8. Service Quality

8.1. Grade of Service for OAO to Vodafone Interconnect Nodes

All Interconnect Links to Vodafone Interconnect Nodes will be dimensioned based on a busy hour grade of service of 0.005 (i.e., 0.5% of offered calls offer across this link will experience congestion). All Interconnect Links from OAO towards Vodafone shall be dimensioned such that, where no capacity is unavailable due to outages, all traffic as per the Service Schedules can be completed via the Interconnect without alternative routing via any PSTNs as per 5.1 above.

8.2. Grade of Service for Vodafone to OAO Interconnect Nodes

All Interconnect Links to OAO Interconnect Nodes will be dimensioned based on a busy hour grade of service of 0.005 (i.e., 0.5% of offered calls offer across this link will experience congestion). All Interconnect Links from Vodafone towards OAO shall be dimensioned such that, where no capacity is unavailable due to outages, all traffic as per the Service Schedules can be completed via the Interconnect without alternative routing via any PSTNs as per 5.2 above.

Annex IV

Switch Port Charges

Vodafone Switch Port Charges	
	€
Per Switch Port Installation	
First Path (New Interconnect Link)	3,303
Additional paths on existing Interconnect Link	1,852
Annual Rental	
First Path (New Interconnect Link)	2,894
For additional paths on existing Interconnect Link	1,549

- Installation charges are one-off charges payable upon installation of the Switch Termination
- Rental charges shall be payable on a quarterly basis in advance
- A minimum of one year rental will apply for all Switch Ports provisioned.

OAO Switch Port Charges	
	€
Per Switch Port Installation	
First Path (New Interconnect Link)	xxxx
Additional paths on existing Interconnect Link	xxxx
Annual Rental	
First Path (New Interconnect Link)	xxxx
For additional paths on existing Interconnect Link	xxxx

- Installation charges are one-off charges payable upon installation of the Switch Termination
- Rental charges shall be payable on a quarterly basis in advance